

# LUMATECH

## Linear Lighting Solutions

### LT100R Recessed-Double Asymmetric

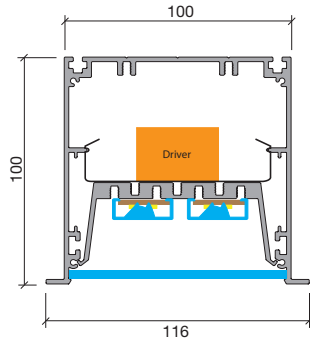
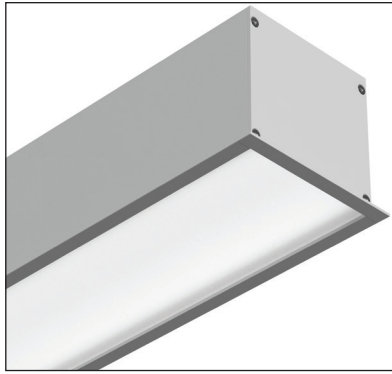

#### DISTRIBUTION

Asymmetric Frosted

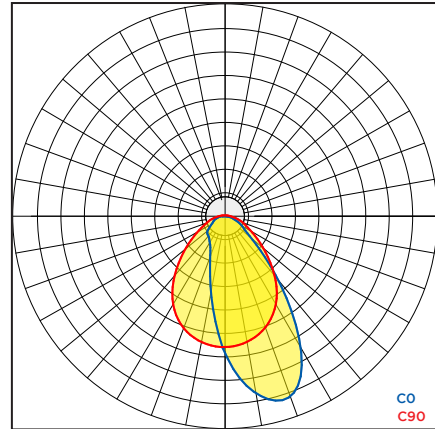

#### FEATURES

- Designed with the installer in mind for a fast & cost effective install.
  - A substantial gear tray provides excellent thermal management ensuring long component life and high lumen maintenance.
  - Choice of screwed or screwless endcaps.
  - High efficacy up to 125Lm/W.
  - Plug & play joining of long runs over 5m.
  - Tridonic LED boards & drivers (3K & 4K as standard) with 2.7K, 5K, 6.5K, Tuneable White 27-65K options & Sunlike full spectrum.
  - Colour consistency 3 MacAdams.
  - L90 @ 50,000hrs B10 & CRI 90 as standard.
  - Certified IES files.
  - Designed & manufactured locally.
  - Where possible components are sourced locally.
  - The 6060 grade aluminium used in the production of these profiles is smelted and extruded in New Zealand.
- The CO<sub>2</sub> emitted per Kg of aluminium produced is one of the lowest in the world.

#### DIFFUSERS

45Deg Primary Lens  
Single Asymmetric



- Geartray Lens
- 95% Transmission
- 45deg Distribution
- Centered 20Deg off vertical

Frosted  
Diffuser

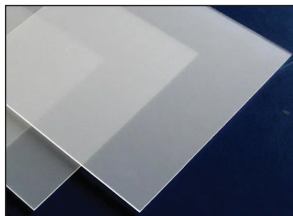

- 92% Transmission
- Homogeneous
- Maintains High CRI

#### CONTROL - DIM - EMERGENCY

Bluetooth



Wireless



Proximity



Emergency



DALI Dimming



DSI Dimming



Switch Dim



Corridor Function



CASAMBI

#### COLOURS

Powder Coat Colours

- Dulux Protecture White (20T1274F)
- Dulux Protecture Black (20T9215F)
- Dulux Protecture Silver Pearl (Light Grey) (21T7852F)
- Custom colours to order

Cast sheet is chosen for diffusers due its greater dimensional stability. Linear lens are PMMA from Tridonic and provide touch protection for non SELV applications.

5  
YEAR

Lumatech Limited, 5/152 Lansford Crescent, Avondale,  
Auckland, New Zealand.

Ph: 09-2813732 Email: sales@lumatech.co.nz www.lumatech.co.nz

# LUMATECH

## Linear Lighting Solutions

### LUMEN/M

CRI90 p/m 4000K			150mA		200mA		250mA		300mA		350mA		400mA		Rows Direct Boards
			Lm	W	Lm	W	Lm	W	Lm	W	Lm	W	Lm	W	
LT100D Low Output	Asymmetric Frosted	Direct	1530	12.5	2040	16.6	2550	20.8	3060	25.0	3572	29.2	4082	33.4	2 x Rows Low Output
LT100D Medium Output	Asymmetric Frosted	Direct	3060	25.0	4082	33.4	5102	41.8	6122	50.0	7142	59.4	8162	66.8	2 x Rows Medium Output
LT100D High Output	Asymmetric Frosted	Direct	4652	37.6	6204	50.0	7754	62.6	9306	75.0	10856	87.6	N/A		2 x Rows High Output
Lumen output for other boards multiply lumens by			CRI90 3000K 0.96				CRI80 4000K 1.18				CRI80 3000K 1.13				
IES Files are standard for 1m. Specific length IES files are available on request. Example 4.7m.															

### JOINS & CORNERS

Profile corners and joins are welded providing a seamless transitions and no light leakage.  
 Custom angled joins on request.  
 Joins can be horizontal or vertical

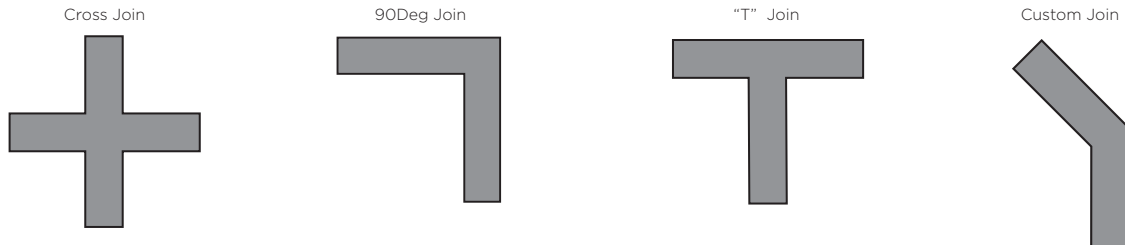

### LENGTH CALCULATION

Luminaires are constructed by using combinations of geartray sizes starting at 565mm and up to 1685mm moving up in 70mm increments. This will give a fully illuminated diffuser from end to end and joins in the profile will be positioned by Lumatech to keep uniform lengths. High output and certain other specialist boards are only available in 280mm increments, please check with us if length is crucial. If a specific length is required in between LED board increments available, these are achieved using blanking plates. Endcap assemblies require a total of 15mm allowance, for recessed luminaires this becomes the cut-out dimension

### ACCESSORIES & OPTIONS

- Plaster recess mounting brackets.
- "T" rail mounting brackets.